

FXi-11 Large Breeze Break A&D Company, Limited

1. Features

The FXi-11 can be installed on the FX-i series balances.
Using the FXi-11 will protect the balance from the effects of a breeze and will provide more accurate weighing results.
An anti-static treatment has been applied to the breeze break components, therefore the weighing error caused by static electricity should not be a problem.

2. Unpacking

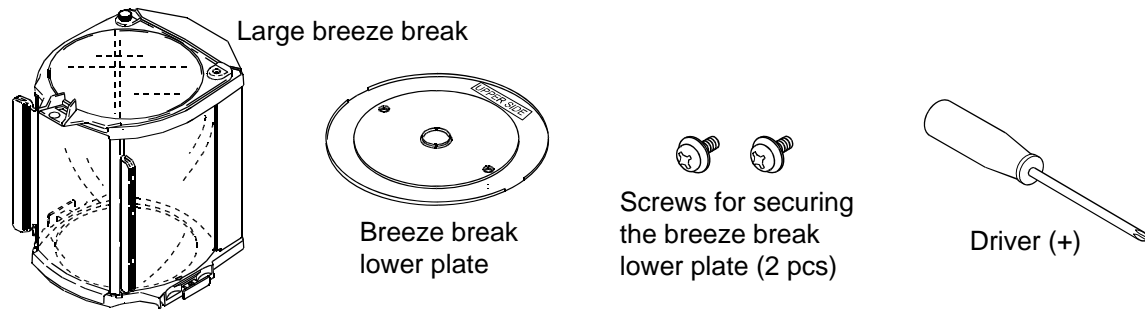

3. Installing the large breeze break

1. Remove the weighing pan and the pan support from the balance.
2. Remove the two screws that secure the dust plate. Remove the dust plate from the balance.

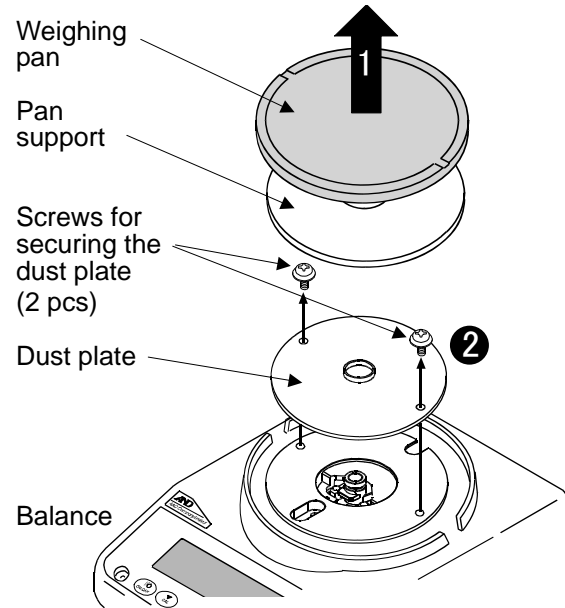

3. Confirm that the "UPPER SIDE" label is visible (up). Using the two screws supplied, install the breeze break lower plate on the balance.

CAUTION
When securing, confirm that the spacing between the inside of breeze break lower plate and the outside of the pan support boss is balanced.

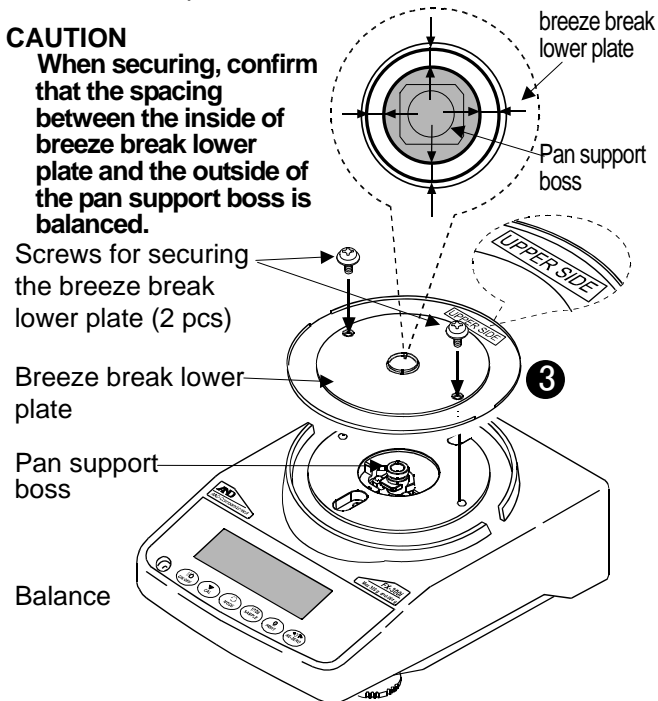

CAUTION - When installing, use care not to apply excessive load to the sensor mechanism (circumference of the pan support boss) of the balance.
- When securing the breeze break lower plate, use the accessory screws provided with the FXi-11. (Keep the original dust plate and screws for later reinstallation.)

4. Pull out the handles located on the each side of the breeze break and install the large breeze break on the balance.
5. Push in the handles from each side.

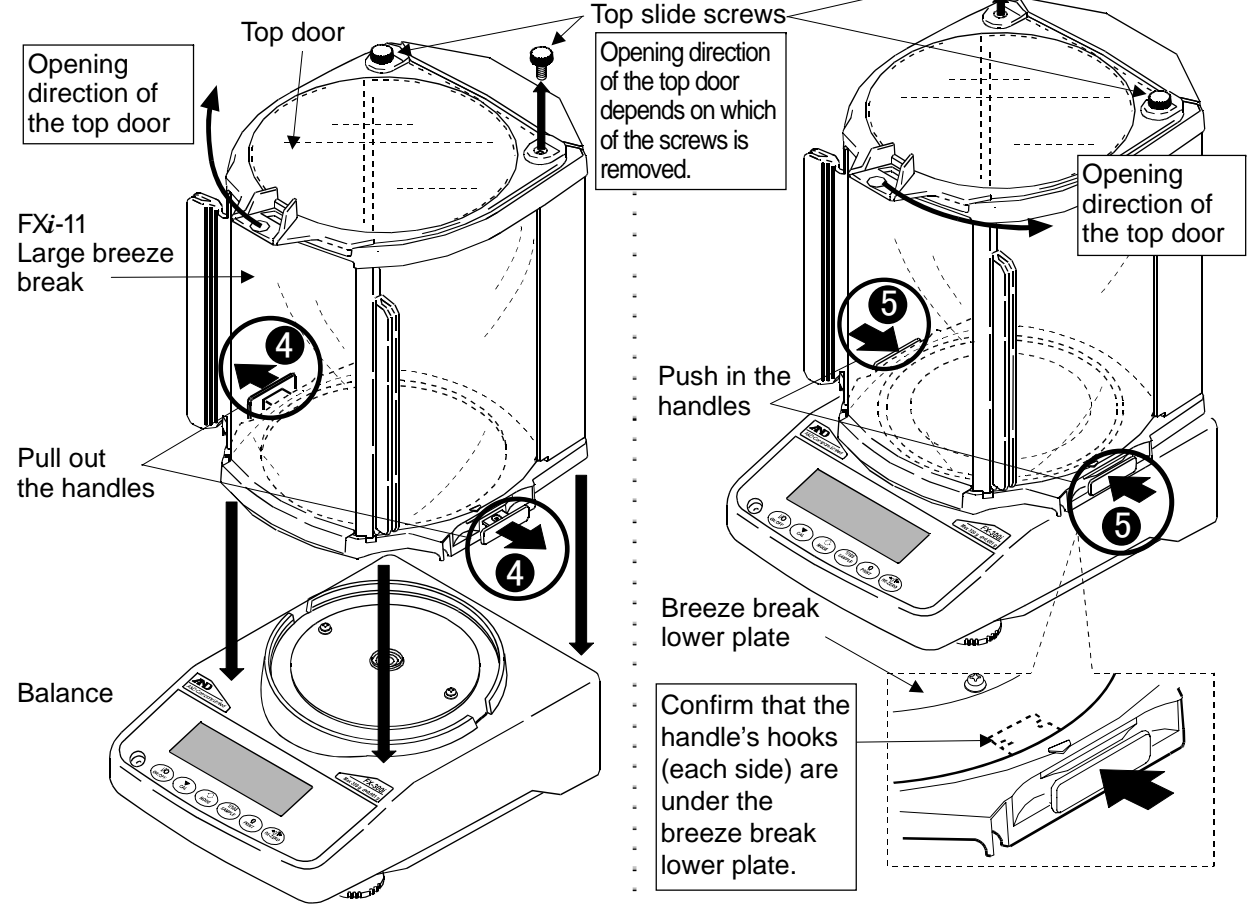

6. Install the pan support on the pan support boss and install the weighing pan on the pan support.

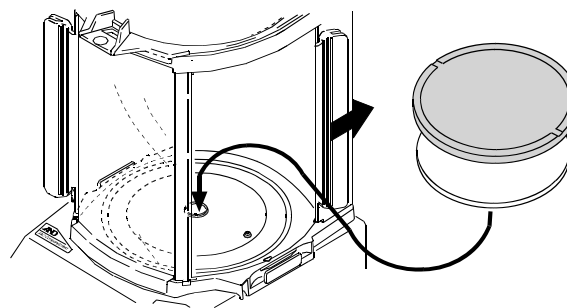

CAUTION - When transporting the balance, do not hold the breeze break. Hold the balance.
- Do not wipe the transparent plastic with solvents such as thinner, benzene or alcohol. It may cause it to turn white.
- An anti-static treatment has been applied to the transparent plastic, therefore do not use solvents such as alcohol to wipe the breeze break.
- When cleaning the breeze break; wipe with a dry, lint free cloth or a lint free cloth that is moistened with warm water and a mild detergent.
- If the anti-static effect decreases, apply an anti-static additive to the transparent plastic.

Materials used (Material of the breeze break)

Transparent plastic: An anti-static treated polycarbonate	Slide pin: Polyacetal	Other plastic: Electro-conductive ABS
Screws: steel	Other metal: SUS	