

User Manual

SLS Lab Basics Inverso TC100 Inverted LED Microscope | MIC0116

This manual is written for the SLS Lab Basics Inverso TC100 Inverted LED Microscope. To ensure safety and optimal performance, it is strongly recommended that you read this manual thoroughly before using the microscope.

For future reference, please keep this manual near your worktable where it can be easily accessed.

www.scientificlabs.co.uk

I Safety notes

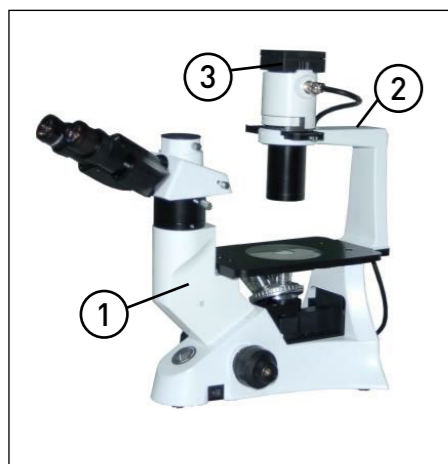

FIGURE 1



FIGURE 2

1. Do not keep the instrument in environments with direct sunlight, high temperatures, humidity, dust, or where it may be subject to shaking. Ensure the stage is level, horizontal, and stable.
 2. When moving the microscope, please hold up the instrument with one hand on the lower side of the eyepiece tube (1), and the other hand on the illumination bracket (2).
 3. In case of spillage on the stage, objective or viewing tube, such as bacterial solutions or water, immediately disconnect the power and clean the affected areas to prevent damage.
 4. When working, the lamp house on the top of the arm (3) (figure 1) will become very hot, be sure there have enough room around the lamp house (especially the top) for cooling.
 5. Prior to replacing the lamp bulb or fuse, switch the main power to the "0" (off) position and disconnect from the power source. If the lamp is on or has been recently turned off and is will be extremely hot and may cause serious burns. Allow it to cool down completely before attempting to replace it.
- ♦ **Bulb specification: halogen lamp 6V30W**
6. Earth this instrument to prevent the risk of electric shock.
 7. Always use the power cord supplied.

II Maintenance



1. Use gauze to gently wipe the glass parts. If necessary, to remove fingerprints and oil stains, slightly dampen the gauze with xylene or a mixture of ethanol and ether in a 3:7 ratio.



Ethanol and ether are highly flammable. Avoid using these chemicals near open flames or potential sources of electrical sparks. Whenever possible, use these chemicals in a well-ventilated area.

2. Do not use organic solvents to wipe the non-optical elements. If cleaning is necessary, use a neutral detergent.
3. When using, if the microscope is splashed by liquid, cut off the power at once, and wipe up the moisture.
4. Do not disassemble any parts of the microscope as this could affect its functionality or performance.
5. If objectives are not mounted, cover with the dust cap to prevent dust and splashed liquid from tissue cultures from entering the interior.
6. When the microscope is not in use, cover it with the dust casing. Ensure the lamp has cooled down sufficiently before doing so.

III Safety symbols

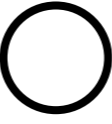
Symbol	Meaning
	The surface is very hot, do not touch with your hands
	Before using, please read the instructions carefully, improper operation will result in bodily injury or instrument function
	The main switch is on
	The main switch is off

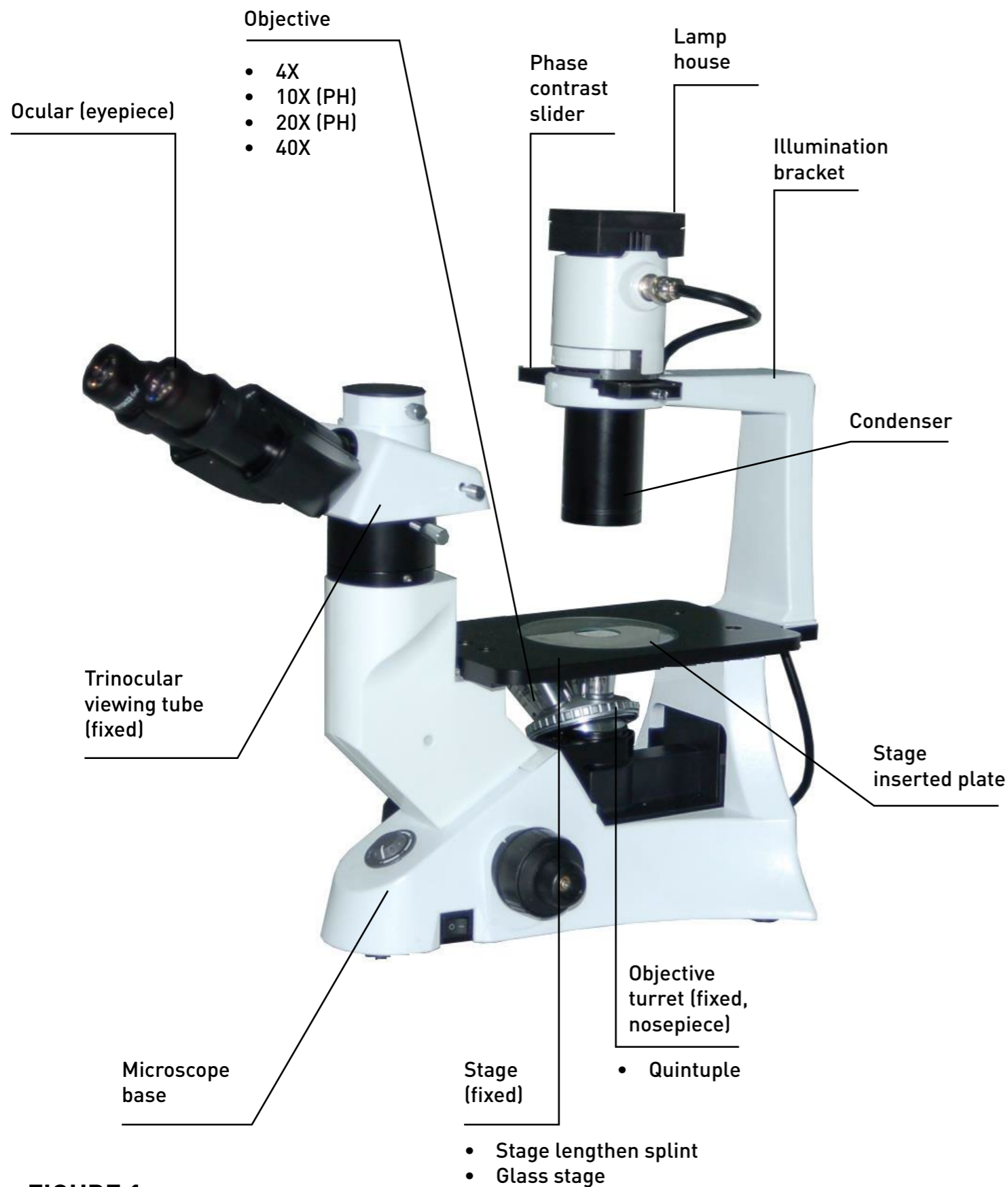

FIGURE 1

2.1 Installation diagram

The following figure shows the installation sequence of the components. The numbers in the figure indicate the installation steps.

- ! Prior to installation, ensure that all components are clean and free from damage. Handle all parts, especially glass surfaces, with care to avoid scratches
- Retain the supplied hexagonal wrench as it is required for component changes or adjustments.

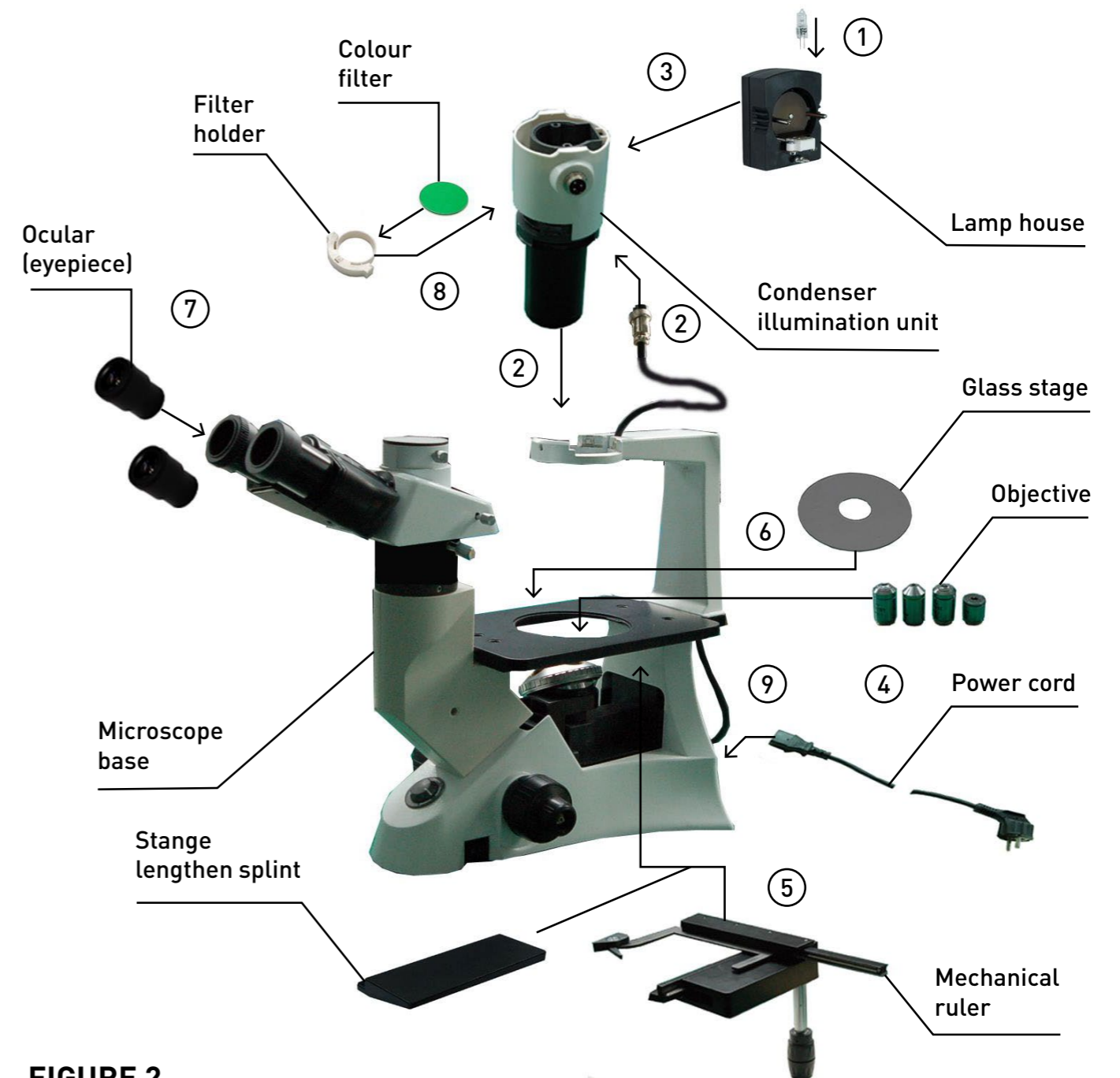

FIGURE 2

2.2 Installation steps

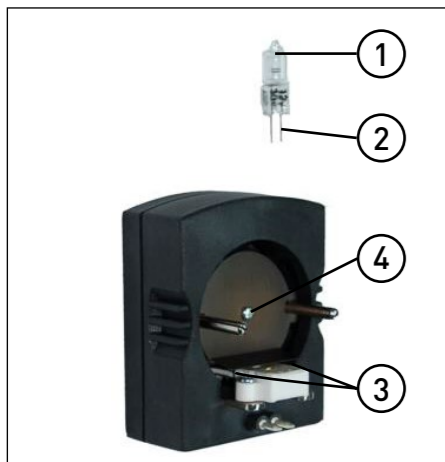

FIGURE 3

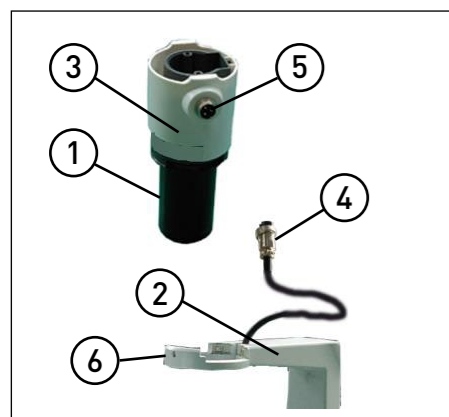

FIGURE 4

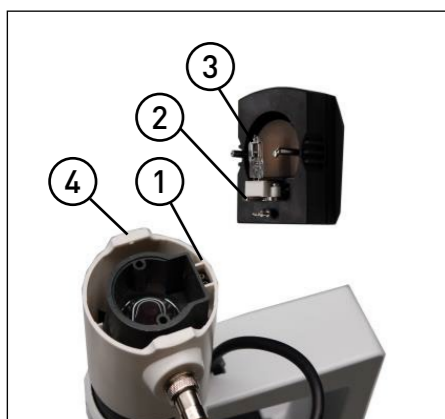

FIGURE 5

2.2.1 Installing and replacing the lamp (Fig. 3)

- ◇ Please use the specified halogen lamp 6V30W
- 1. Hold the bulb (1) with a protective material such as gauze, then insert the plugs (2) into the jack (3) on the lamp house, ensuring the filament is level with the bolt (4).
- 2. Do not replace the lamp when using the microscope or soon after it is turned off, as the bulb, lamp house and nearby parts will be very hot and will cause serious burns. Before replacing the lamp, turn the main switch to "0" (off), remove the power plug, and make sure the bulb, lamp house and periphery are all cool.



- Please insert the lamp gently, as it may be damaged by excessive force.
- Avoid touching the bulb directly; this can shorten its lifespan or cause it to break. If touched, clean with a dry soft cloth.

2.2.2 Installing the condenser illumination unit (Fig. 4)

1. Gently insert the condenser illumination unit (1) into the bracket (2) as shown in figure 4.
2. Rotate the condenser illumination unit clockwise approximately 90 degrees until the "AS" mark of the filter holder (3) faces forward. Align the screw of the condenser illumination unit and the hole of the holder, then secure the bolt with the supplied hexagonal wrench.
3. Insert aviatric BNC connector plugs (4) into aviatric BNC connector jack (5).

2.2.3 Installing the lamp house (Fig. 5)

Align the BNC connector plugs (1) with the lamp house pin (2), and the bolt (3) with the condenser jack (4). Then gently push the lamp house into the illumination unit until they are properly against one another.



FIGURE 6

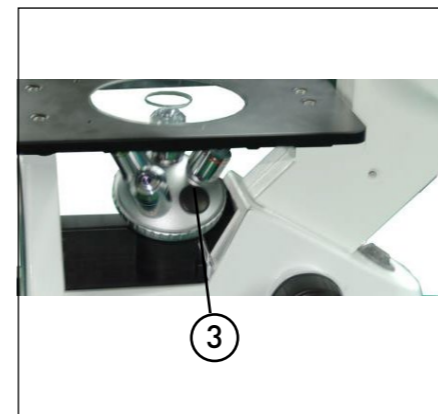

FIGURE 7

2.2.4 Installing the objective (Fig. 6 & 7)

1. Turn the coarse focusing knob (1) as shown in the figure until the nosepiece reaches its lowest position.
 - ◇ To ensure safety during transportation, the nosepiece is located in the lowest position and the tension adjustment collar is adjusted to an appropriate tight tension before leaving the factory.
2. Screw the lowest magnification objective onto the turret from the nearside. Then, turn the turret clockwise and mount the other objectives in order of increasing magnification from low to high.
 - ◇ Mounting objective in this way will make the change of magnification easier to use.
 - ◇ You can also install the objective through the stage opening.



- Clean the objectives regularly, as they are very sensitive to dust.
- Cover all the unused holes with turret dust caps (3), to prevent the dust and contamination entering inside.
- When operating, use the low magnification objective (4X or 10X) to search and focus the specimen at first, then replace the higher magnifications if necessary.
- When replacing the objective, slowly turn the nosepiece until you hear a "click". This means the objective is in the correct position in the centre of the light path.

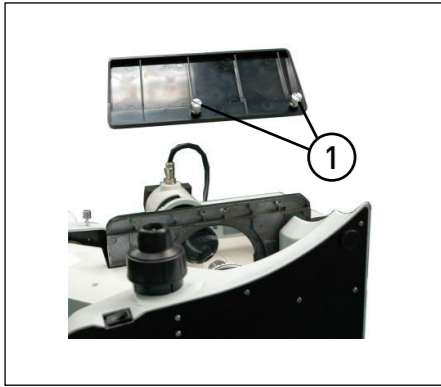

FIGURE 8

2.2.5 Installing the stage lengthen splint and the mechanical ruler (Fig. 8)

- ◇ Stage lengthen splint can be installed on either side of the stage to enlarge the work surface. But you can't install the mechanical ruler at the same time.
- ◇ Generally, the mechanical ruler will be installed on the right side for comfortable adjustment.

1. Installing the stage lengthen splint

First, screw the fixed bolt (1) onto the splint, then mount it on to the stage from right or left below, screwing down it until it stays firm.

2. Installing the mechanical ruler

Please install the ruler in the same way as the stage splint.

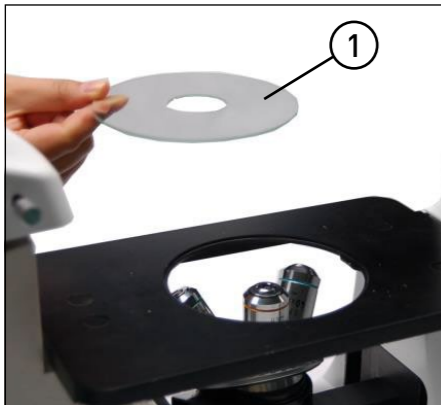

FIGURE 9

2.2.6 Installing the stage inserted plate (Fig. 9)

1. When using the glass stage (1), there are no special requirements; simply place it flat on the stage.
2. Install the stage inserted plate on to the stage opening.
3. Turn the disk, so that the V nick faces the user, so the recognition of the objective will be easier.

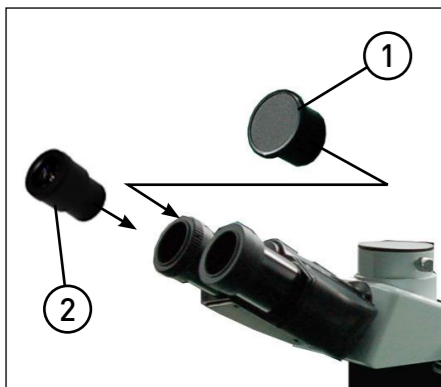

FIGURE 10

2.2.7 Installing the eyepiece (Fig. 10)

1. Remove the cap of the eyepiece tube (1)..
2. Insert the eyepiece into tube until they are together.

2.2.8 Installing the colour filters (Fig. 11)

! Be sure the colour filter have cooled down completely before you change them. Take down the filter holder (1), then install the colour filters (2) you need.

Mount the colour filter downwards as shown (3), ensuring it is horizontal and fully inserted to prevent it from dropping.

! If the colour filter is inclined or does not get to the end (4), it may drop.

Multiple filters can be stacked on the holder as long as the total thickness does not exceed 11mm.

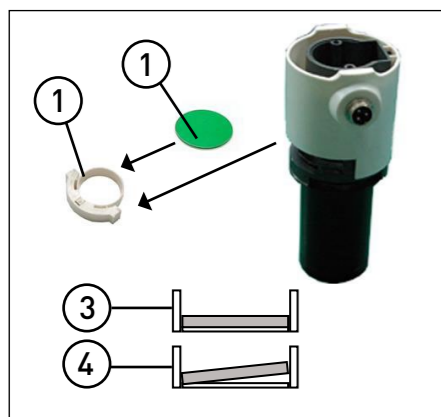

FIGURE 11

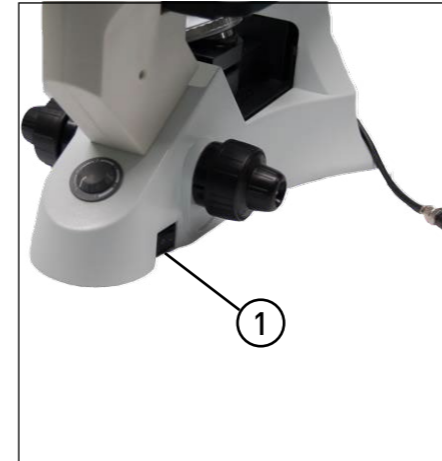

FIGURE 12

2.2.9 Connecting the power cord (Fig. 12, 13 & 14)

! Avoid placing undue stress on the power cord, as bending or wrapping it tightly can cause damage

1. Before connecting the power cord, ensure the main switch (1) is in the "0" (off) position.
 2. Insert the plug (2) into the power jack (3) of the microscope safely.
 3. Plug the power cord (4) into the power supply receptacle (5).. Make sure the connection is secure.
- Insert aviatic BNC connector plugs (9) into aviatic BNC connector jack (8).

! Use the supplied power cord at all times. If a replacement is necessary, choose a cord of the same standard.

- Ensure the power cord is connected correctly to provide proper earthing to the instrument.

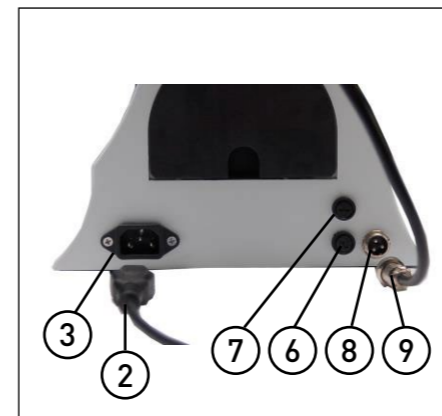

FIGURE 13

2.2.10 Replacing the fuse (Fig. 12 & 13)

Before replacing the fuse, turn the main switch (1) to the "0" (off) position, and unplug the power cord. Use a screwdriver to rotate the fuse (6) kits out of the holder (7), replace with a new fuse, and then secure it back into place.

Fuse rating: 250V, 500mA.

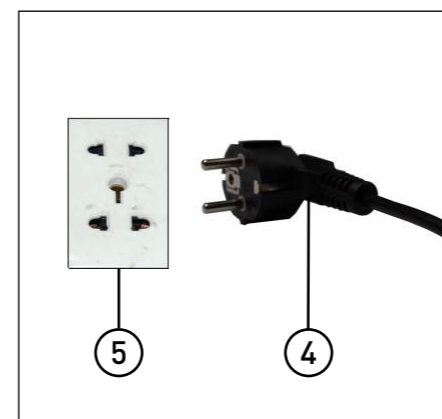
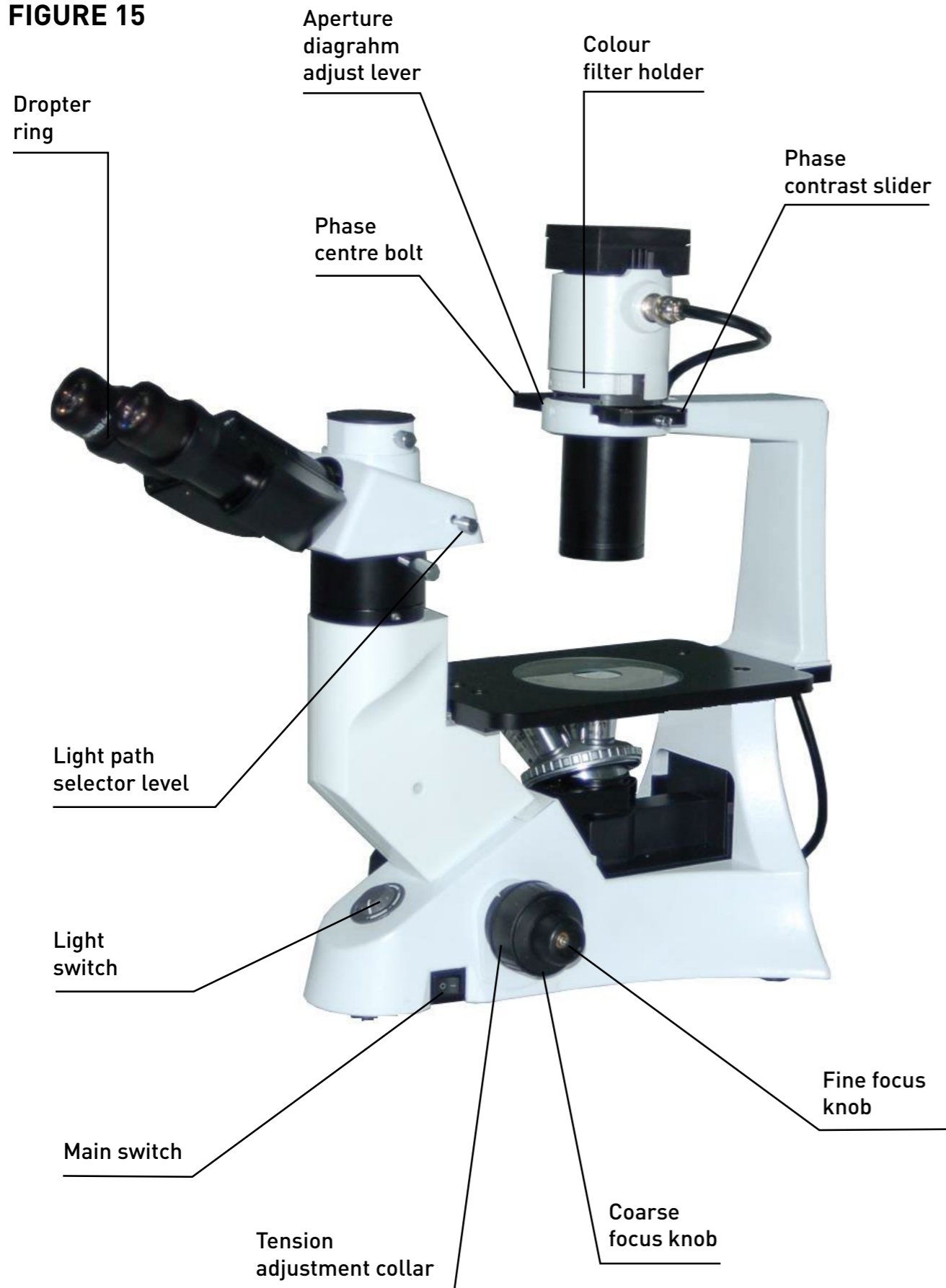

FIGURE 14

FIGURE 15



4.1 Microscope base

4.1.1 Turning on the lamp (Fig. 16)

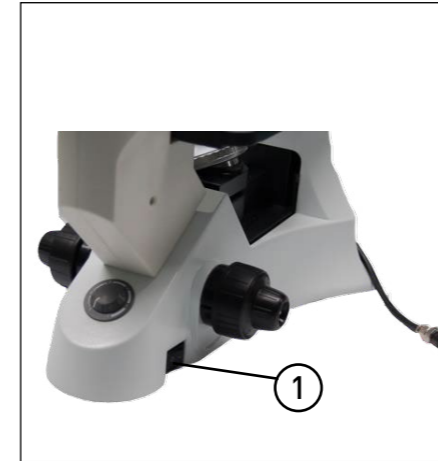

FIGURE 16

Connect the power and turn the main switch (1) on the bottom side of the base to “-” (on).

4.1.2 Adjusting the brightness (Fig. 17)

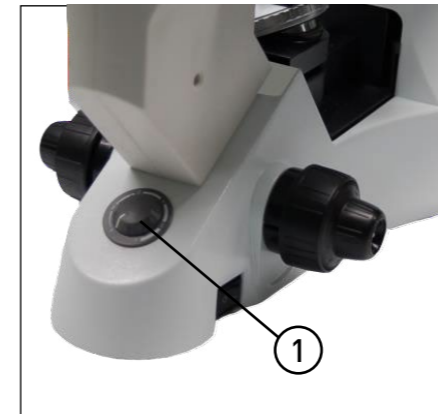

FIGURE 17

Adjust the brightness by turning the brightness adjustment knob. Clockwise rotation increases voltage and brightness, while anti-clockwise rotation decreases voltage and brightness.



Using the lamp in a low voltage condition, will prolong the service life.

4.1.3 Adjusting the tension adjustment collar (Fig. 18)

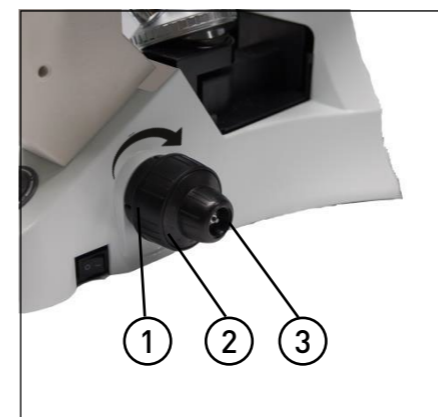

FIGURE 18



The tension of the coarse focus knob (2) has been pre-adjusted at the factory.

How to adjust the tight tension:

Turning the tension adjustment collar (1) in the direction shown by the arrow on the figure, will increase the tension of the coarse focus knob (2). Turning it in the opposite will decrease the tension.

If the nosepiece drops automatically, or the specimen defocuses despite focusing with the fine focus knob (3), it means the coarse focus knob is too loose. Turn it in the direction of the arrow shown in figure 18.

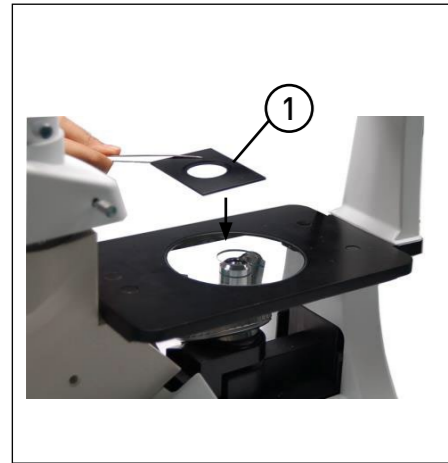

FIGURE 19

4.2.1 Setting the specimen (Fig. 19 & 20)

Set the specimen in the centre of the stage. To obtain the best observation results, select containers such as culture dishes and culture bottles with a bottom thickness of 1.2mm. The same thickness is also required for the object slide when placing the specimen.

Using the Ø35mm culture dish

You can lay a Ø35mm culture dish on the stage directly by using the standard centre board (1) of the stage.

Using the mechanical ruler

1. When using the 96bit or 24bit micro-titration board, please fasten it tightly by the stage clips (2).
2. When fastening other model boards, please use the following supplied brackets with mechanical ruler:
 - ◇ Terasaki bracket (3) for Terrasaki board
 - ◇ Culture dish bracket (4) for Ø35mm culture dish
 - ◇ Object slide bracket (5) for object slide and Ø54mm culture dish
3. Turning the transverse knob (6) and lengthways knob (7), move the specimen to the required position (movement range, width x length: 120 × 78mm).

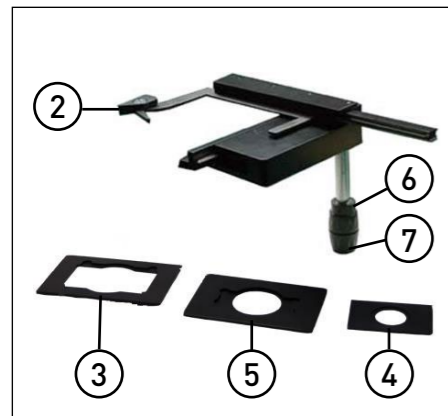

FIGURE 20

4.2.2 Moving the specimen

Turn the knob of the mechanical ruler or manually move the specimen to the position required.

Be careful when you replace the objectives, especially after a short work distance observation. Do not let the objective to touch the stage inserted plate or the culture dish bracket.

4.3 The viewing tube

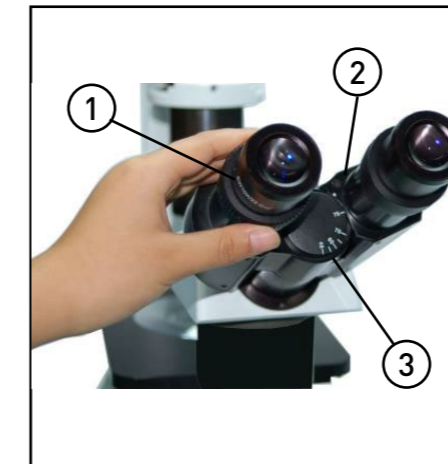

FIGURE 21

4.3.1 Adjusting the diopter (Fig. 21)

Look into the right eyepiece by your right eye, then revolve the coarse focus knob to focus on the specimen. Then use your left eye to look into the left eyepiece. If the image is not sharp, use the diopter adjustment ring (1) to adjust.

! There are ±5 diopter in the adjustment ring (1). The number which the reticle on the eyepiece holder pointed is your eye's diopter graduation.

4.3.2 Adjusting the interpupillar distance (Fig. 22)

When observing with both eyes, hold the left and right prism holder, turn around the axis, adjusting the interpupillar distance until the left and right fields of view coincide completely.

! The reticle on the interpupillar distance indicator (3), pointed by the spot "." (2) on the eyepiece holder, shows the scale of the interpupillar distance (fig. 21).



FIGURE 22

The range of the interpupillar distance is 48–75mm.

4.3.3 Switching the light path (Fig.23)

- ◇ Pulling out the light path selector lever (1) using your thumb, select the light path required.
- ◇ When in the binocular observation, push in the lever until you hear a "click". While in video or photography, pull out the lever until it reached the "clicked" position.



FIGURE 23

Light path selector lever	Brightness proportion	Application
Pushing in the lever until it reached the limit position	100% used for binocular observation	Binocular observation
Pulling out the lever until it reached the limit position	20% used for binocular observation, and 80% used for video or photography	Binocular observation, television, and micrography or video can be operated simultaneous

4.4 Illumination unit

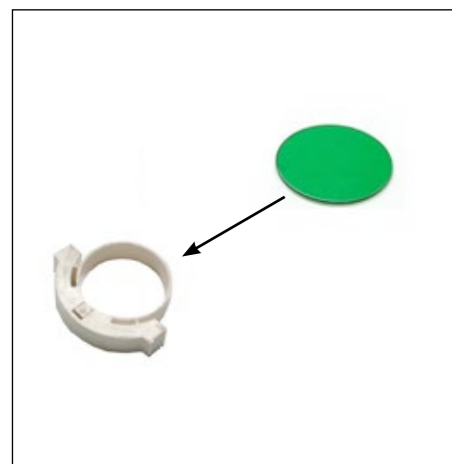

FIGURE 24

4.4.1 Using colour filters (Fig. 24)

- ◇ Select the appropriate colour filters according your need, to effectively to observe or photograph the specimen. Using the LBD colour filter is suggested, as it can compensate more neutral colours.
- ◇ Multiple filters can be stacked on the holder as long as the total thickness does not exceed 11mm.

Colour filter	Meaning
IF550	Single contrast colour filter (green) (used for the phase contrast microscopy)
LBD	Colour temperature transit colour filter (blue) (used for bright field observation and microphotography)

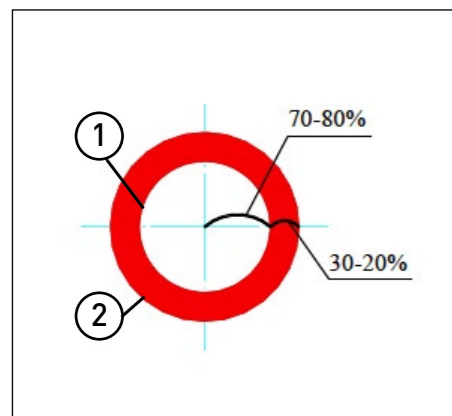

FIGURE 25

4.4.2 Using the aperture diaphragm (Fig. 25)

In bright field observation, the aperture diaphragm controls the numerical aperture of the illumination system. To achieve higher image resolution, contrast, and increased depth of field, the numerical apertures of both the objective and the illumination system must match.

To identify the aperture diaphragm, you can remove the eyepiece if necessary (or insert in the centre telescope), and look into the viewing tube. You should see a field of view similar to the figure shown. The proportion can be adjusted by dialling the aperture adjustment lever as needed. ((1) represents the image of the aperture diaphragm, and (2) indicates the edge of the objective).

Generally, when observing the chromatic specimen, you need to set the size of the condenser aperture diaphragm at 70%–80% of the numerical aperture which marked in the objective. However, when observing non-coloured bacterial specimens, turn the aperture diaphragm lever clockwise

5.1 The name of the components



FIGURE 26

5.1.1 Phase contrast objective (Fig. 26)

- ◇ The optional magnification of the phase contrast is :10X, 20X
- ◇ If you want to know how to mount the phase contrast objective, please see 2-2-4. You should to mount it on the turret.

5.1.2 Phase contrast slider (Fig. 27)

Phase centering adjustable slider:

- ◇ The light ring was centred beforehand, so it does not need to be adjusted during use. If the ring is not centred, you can adjust it using the centring bolt.
- ◇ The 10X/20X light ring (1) is used with the 10X,20X phase contrast objective, while the opening (2) is used for bright field

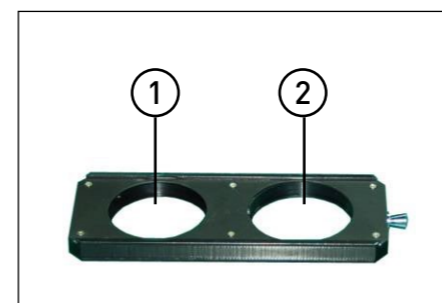

FIGURE 27

5.2 The installation and use



FIGURE 28

5.2.1 Installing the phase contrast slider (Fig. 28)

1. Insert the slider (1) with the surface that has the characters facing up, into the illumination system from right to left, as shown in the figure.
2. Each light ring or opening has its own designated position, so move them until you hear a “click” to ensure the ring or opening is centred in the light path.
3. For phase contrast observation, keep the aperture diaphragm adjustment lever (2) in the “0” (off) position (wide open).

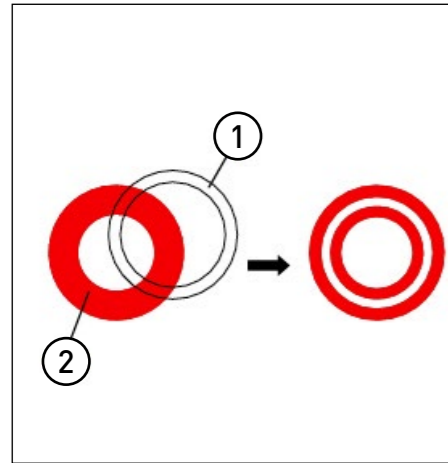

FIGURE 29

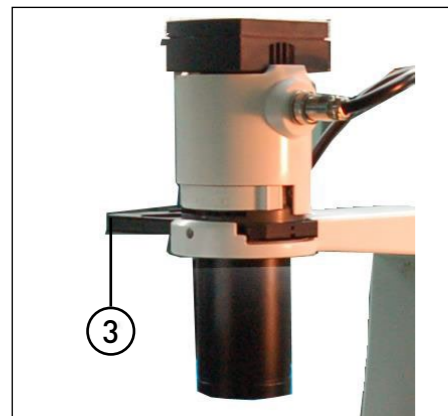

FIGURE 30

5.2.2 The centering ring (Fig. 29 & 30)

Usually, centring is not necessary. If required, please follow these steps:

1. Place the specimen on the stage and focus it.
2. Remove the eyepiece and replace it with the CT (centring telescope), inserting it into the viewing tube without adjusting the diopter.
3. Ensure the matched phase contrast objective and light ring (in the phase contrast slider) are centred in the light path.
4. Use the CT to view the light ring's image (1) and the phase contrast ring's image (2). If the light ring's image is not sharp, adjust the CT's eyepiece until the image of the light ring (2) is clear.
5. Using a screwdriver, adjust the bolts of the two centring holes (3) in the phase contrast slider until the centre of the light ring coincides with the centre of the phase contrast ring.
6. The 10X and 20X phase contrast objectives use the same light ring on the phase contrast slider. Check the coincidence of the light ring centre and the phase contrast centre when changing the objective. If there is any misalignment, re-centre them.

- ◇ If the light ring is not correctly centred, you will not achieve the best viewing effect with the microscope.
- ◇ After removing or replacing a thick specimen, the light ring and the phase contrast ring may become misaligned, resulting in reduced image contrast. If this occurs, please repeat the steps outlined above.
- ◇ If the container or cover slip used to place the specimen is not flat, you may need to repeat the centring steps to achieve optimal contrast. Centre the light ring using the phase contrast objective, starting with low magnification and progressing to higher magnification.

6.1 Microscope video

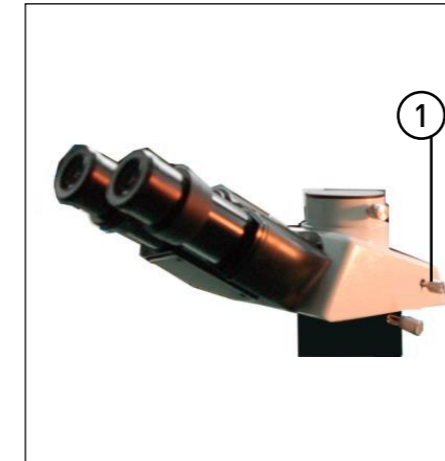

FIGURE 31

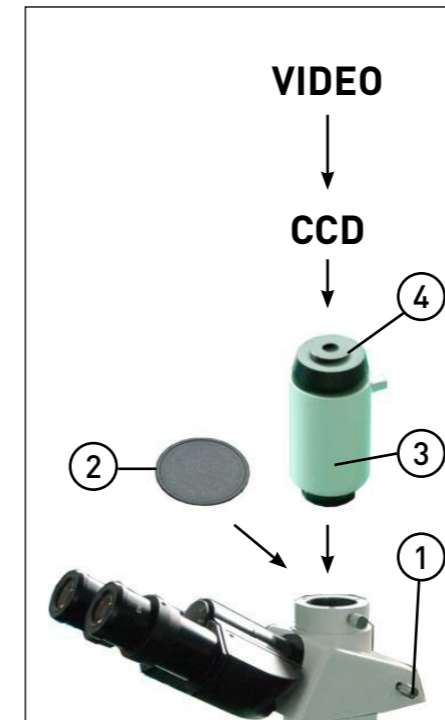
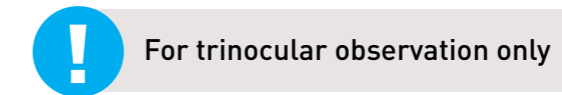

FIGURE 32

6.1.1 Selecting the light path (Fig. 31)



For trinocular observation only

Pull out the light path selector lever until you hear a "click."

- ◇ For dark specimen observation, first focus using both eyes, then change the light path.

6.1.2 Installing the video set (Fig. 32)

1. Loosen the locking bolt (1) on the trinocular viewing tube and remove the dust cap (2).
2. Remove the dust covers from both ends of the video accessory (3), and screw the head end into the CCD/CMOS port.
3. Install the accessories into the tri-through port and tighten the bolt (1).

6.1.3 Focusing (Fig. 32)

Conduct a binocular observation at 20% brightness. View the image on the video or computer connected to the microscope video system. If the image is not in focus, turn the revolving video connection tube (4) until the image is sharp.

6.1 Microscope video

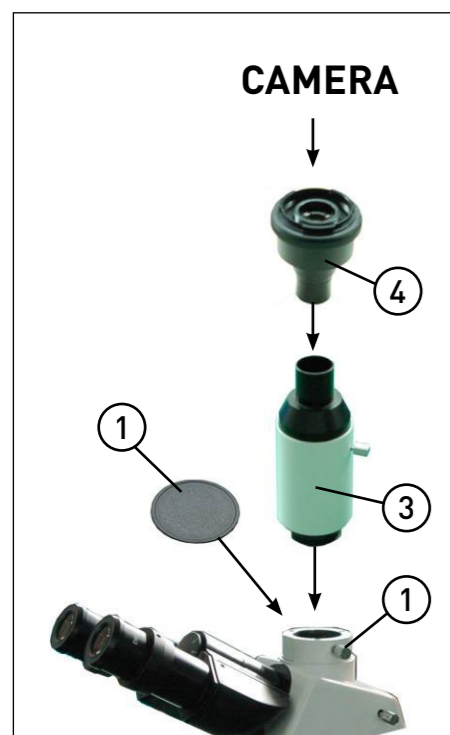

FIGURE 33

6.2.1 Selecting the light path



For trinocular observation only

Refer to the operation diagram in 6.1.1 and the details in section 4.3.4.

6.2.2 Installing the photography set (Fig. 33)

1. Loosen the locking bolt (1) on the trinocular viewing tube and remove the dust cap (2).
2. Install the photography accessory (3) into the tri-through port and tighten the locking bolts (1).
3. Insert the camera gate on the digital photography connection head (4) into the corresponding position of the camera set port and screw it down clockwise.
4. Plug the digital photo connection head into the photo tube and tighten the locking bolts (1).

- ◇ Before connecting the camera and adapter, first remove the camera lens, then connect the lens port with the adapter, paying attention to the gate type.
- ◇ To avoid interference from the eyepiece during observation, place the viewfinder on either side of the microscope when installing the camera set.
- ◇ Camera magnification = Objective magnification × Camera lens magnification
- ◇ When taking micrographs, the closing of the lens may impact some cameras. To mitigate this and obtain a clear image, you can select a longer exposure time or decrease the brightness as compensation.
- ◇ This explanation is for Nikon single-lens reflex digital camera.

6.2.3 Focus

Perform binocular observation at 20% brightness and focus initially. When using the microscope for photography, use the camera viewfinder to focus on the specimen. Refer to the user manual of the camera set for detailed instructions.

6.2.4 Adjusting the colour temperature

When capturing chromophotographs, use the sunlight film.

1. Attach the LBD temperature-changed colour filter to the colour filter bracket.
2. Turn the brightness adjustment knob to the maximum position to achieve sunlight illumination.

7.1 Main specifications

Optical system	Infinite Optical System
Viewing Tube	Compensation Free Trinocular Tube Inclined at 30°; Division ratio: 20% of Binocular Viewing and 80% of Video Viewing & Micrography
Eyepiece	Wide Field Eyepiece 10X, Linear Visual Field: 22 mm
Nosepiece	Backward Quintuple Nosepiece
Objective	Infinite Long Working Distance Plan Achromatic: 4X, 40X Infinite Long Working Distance Plan Phase Contrast: 10X, 20X
Focusing System	Coaxial Coarse and Fine Focusing System Sensitivity and Graduation of Fine Focus: 0.002mm Movement Range(from the surface focus of stage plate): up 8mm, down 3mm
Stage	Area: 160 width × 250 Length mm
Mechanical ruler	Movement Range: 120 width × 78 Length mm
Illumination	Halogen Lamp 6V30W, Preset Center, Intensity continued Adjustable
Condenser	Long working Distance Condenser, Numerical Aperture 0.3, Working Distance 72mm
Operation environment	<ul style="list-style-type: none"> • Use indoor • Altitude: Maximum 2000m • Temperature: 5°C~40°C (41°F~109°F) • Maximum Relative Humidity: 80% at 31°C (88°F), then Fall Linear • 70% at 34°C (93°F), 60% at 37°C (104°F), 50% at 40°C (104°F) • Pollution Degree: 2 (refer to IEC60664)

7.2 Objective specifications

TYPE	MAGNIFICATION	NUMERICAL APERTURE (N.A)	WORKING DISTANCE (mm)	CONJUGATE DISTANCE (mm)	FOCUS DISTANCE (mm)	COVER SLIP THICKNESS
Infinite Long Working Distance Plan Achromatic Objective	4X	0.10	17.3	∞	45	-
	40X	0.6	2.1	∞	45	1.2mm
Infinite Long Working Distance Plan Phase Contrast Objective	10X	0.25	10.0	∞	45	1.2mm
	20X	0.4	5.1	∞	45	1.2mm

Under certain conditions, certain non-fault factors can temporarily affect the instrument's performance. If an issue arises, please refer to the following table for appropriate measures. If the problem persists despite these solutions, please contact our company's sales department for further assistance.

PROBLEM	REASON	SOLUTION	PAGE
I. Optical			
1. The illumination is on, but the field of view is dark	The plug of the lamp holder is not connected to the illumination set	Connect them securely	6
	The bulb burnt out	Replace with a new bulb	6
	The brightness is too low	Adjust to a proper position	11
	The colour filter is stacked too high	Reduce the number of the filters	14
	Not using the specific lamp bulb	Use the specified halogen lamp 6V 30W	6
2. The edge of the field of view has shadow or the brightness is asymmetrical	The nosepiece is not in the correct position	Turn the nosepiece until you hear a "click"	7
	The colour filter is not fully inserted	Insert the colour filter until it is securely in place	14
	The phase contrast slider is not in the proper position	Turn until you hear a "click"	15
3. There is dust and stains in the field of view	There are stains on the specimen	Change to a clean specimen	-
	There are stains and dust on the eyepiece	Clean the eyepiece	-
4. Images appear double	The size of the aperture diaphragm is too small	Open up the aperture diaphragm	14

5. Resolution problems: <ul style="list-style-type: none"> Image is not sharp The contrast is not high The detail is not clear Unable to obtain phase contrast effect 	The nosepiece is not in the centre of the light path	Turn the nosepiece until you hear a "click"	7
	The aperture diaphragm in the view of field is opened too large or too small	Adjust the aperture diaphragm correctly	14
	The lens (condenser, objective, eyepiece or culture dish) has become dirty	Clean to remove dirt	-
	In the phase contrast observation, the bottom thickness of the culture dish is more than 1.2mm.	Use a the culture dish with a bottom thickness is less than 1.2mm	12
	Use a bright field objective	Change to the phase contrast objective	15
	The condenser ring is not aligned with the objective phase ring	Adjust the condenser ring to match the objective phase ring	15
	The light ring and the phase contrast kit is not centered	Adjust the bolts to centre them	15
	The objective used is not fit for the phase contrast observation	Use the compatible objective	15
6. One side of the image is unfocused	When looking at the edge of the culture dish, the phase contrast ring and the light ring is not aligned	Move the culture dish until you obtain the phase contrast effect. You also could demount the slider, and dail the field diaphragm with the direction of "⊙"	16
	The nosepiece is not in the centre of the light path	Ensure the nosepiece is in the "clicked" position	7
	The specimen isn't placed properly	Place the specimen on the stage correctly	12
The optical performance of the culture dish bottom is poor	Please use a regular culture dish	-	

PROBLEM	REASON	SOLUTION	PAGE
II. Mechanical			
1. The coarse focus knob is hard to turn	The tension adjustment collar is too tight	Loosen properly	11
2. The image can't stay in focus during observation	The tension adjustment collar is too loose	Tighten properly	11
III. Electric			
1. The lamp won't turn on	No power supply	Check the power cord, and connect them properly	9
	The installation of the bulb is wrong	Install the bulb correctly	6
	The bulb is burnt out	Replace with a new bulb	6
2. The bulb burns out at a high frequency	Not using the specified lamp	Use the specified lamp	6
3. The brightness is too low	The brightness adjustment knob is used wrong	Adjust the brightness adjustment knob in the correct way	11
4. The bulb is flickering	The bulb is going to burn out	Change the bulb	6
	The power cord has poor contact	Check the power cord, and connect it properly	9

PROBLEM	REASON	SOLUTION	PAGE
IV. Viewing tube			
1. The field of view is different between the two eyes	The interpupillar distance is not correct	Adjust the interpupillar distance	13
	The diopter is not right	Adjust the diopter	13
	Difficulty adapting to microscope observation	When looking through the objective, avoid staring solely at the specimen; instead, view the entire field of vision, shift focus away to observe surrounding elements before returning to the objective	1
V. Microscope video			
1. The image is unfocused	Focus is incorrect	Adjust the focus until both the double reticle and the specimen are clearly distinguishable	13
2. There is faintness around the image	It is an inherent character of the achromatic objective	The problem is unavoidable if you use an achromatic objective	-
3. The indoor window or the fluorescence lamp develop	The extra light entering into the eyepiece and viewfinder is reflected	Cover the eyepiece and the viewfinder of the microscope illumination system	-



User Manual
SLS Lab Basics Inverso
TC100 Inverted LED
Microscope | MIC0116

Brought to you by



Scientific Laboratory Supplies
Unit 6 Fairham Business Park
Foresters Avenue
Fairham
Nottingham
NG11 2AF

Tel: +44(0) 115 982 1111
slsinfo@scientific-labs.com
www.scientificlabs.co.uk