



Technical Data Sheet

High Performance General Purpose Freezer

Revision-0

Thermo Fisher Scientific, Asheville, North Carolina

Specifications	Catalog number
	TSX1230FV
Model Number	TSX1230FV
Application, Rating and Electrical Data	
Application	Storage of General (non-flammable) Laboratory Materials
Storage Volume	326 Liters / 11.5 Cubic Feet
Factory Set Point	-30°C
Set Point Range/Adjustable Increment	-35°C to -15°C / 0.1°C
Electrical Power / Rated Current	208-230V 50 Hz 1 Phase / 3.25A
Building Supply Rating	15A dedicated grounded non-GFCI circuit. Protected by circuit breaker rated for inductive loads
Power Plug/Power Cord Length	16 Amp (CEE 7/7) / 3.048 Meters (10 feet)
Agency Listings	CE, UL, cUL
Indoor/Outdoor Usage	Indoor Use Only
Application Environment	Non-Corrosive, Non-Flammable, Non-Explosive, Good Air Ventilation
Ambient Operating Temperature	15° C - 32° C (60° F - 90° F)
Refrigeration Configuration	
Refrigeration System	Vapor compression system
Compressor / Number / Capacity	Hermetic Variable Capacity Compressor / 1 / 398W
Condenser Type/Number	Enhanced Finned-Tube and Forced-Air Cooled / 1
Expansion Device	Capillary Tube
Evaporator Type / Defrost Method	Forced Air Evaporator Coil / Automatic Defrost
Refrigerant Charge / Flammability	R290, 95gms, GWP:3 ODP:0 / Flammable
Controller/Electrical System Configuration and Features	
Controller Level	Eye Level
Power Switch	Keyed Off-On - Alarm
Controller Type	IntrLogic Control System: Digital display, Graphic thermometer, Automatic defrost system
Setpoint Security / Programmable	Yes / Yes
Compressor Safe Guard	Current protection
Control Sensor	Single RTD (1000 ohm shielded Platinum RTD)
Connectivity / Remote Outputs	Remote alarm contacts, RS485 output and 4-20 mA output (optional)
Adjustable Warm / Cold Alarms	Fully Adjustable
Power Failure Alarm	Standard
Electronic Chart Recorder	Optional
Dimensions and Construction	
Interior Dimensions (D x W x H)	55.4 cm x 50.8 cm x 133.1 cm (21.8" x 20.0" x 52.4")
Exterior Dimensions (D x W x H)	79.0 cm x 61.9 cm x 185.4 cm (31.1" x 24.0" x 73.0")
Insulation	5.08 cm (2.0") High-Density Water-Blown Polyurethane Foam
Door Perimeter heater	Yes
Shelves / Load Limit	(4) Adjustable Wire Shelves / Max. Cap. per Shelf: 45 kg (100 lbs.)
All-Direction Casters	Standard with Locks
Shipping Weight	152 kg / 335 lb

Typical Performance Characteristics

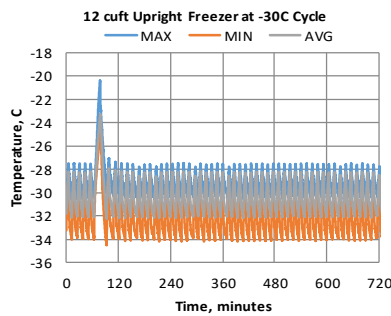
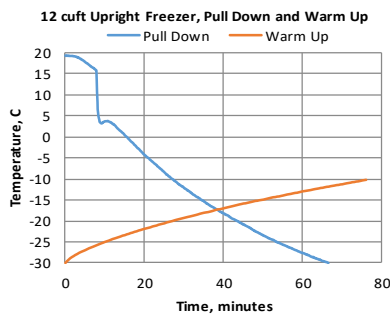

Test Unit Series Number or MSO Number:	19758-B-20-1
Cabinet Load:	Unloaded
Average Cabinet Temp at -30C Cycle (C):	-30.3
Peak Variation from Setpoint (C):	+9.6 / -4.5
Uniformity (C):	2.9
Stability (C):	9.5
1-min Door Opening Recovery to -30C (min):	10
Duty Cycle at -30C (%):	68
Cycle (on/off) rate at -30C (min):	9 / 4
Energy Consumption (kw-hr/day):	6.4
Heat Rejection Rate (btu/hr):	913
Pull Down Time (to -30C) (min):	67
Warm Up Time (-30C to -10C) (min):	76
Sound (dBA):	52

- 1) Performance is nominal and individual units may vary.
- 2) Product performance will differ due to product amount, product size and operating conditions.
- 3) Continuous product enhancements may, without notice, result in amendments or omissions to this specification. Thermo Scientific cannot accept responsibility for damage, injury, loss or expenses resulting from misapplication of the information herein.

Typical Cabinet Temperature Map
Freezer 12cuft , 4 Inner-Shelves + Base, Single Outer Door

Temperatures are averages during > 20 cycles after reaching a setpoint of -30C

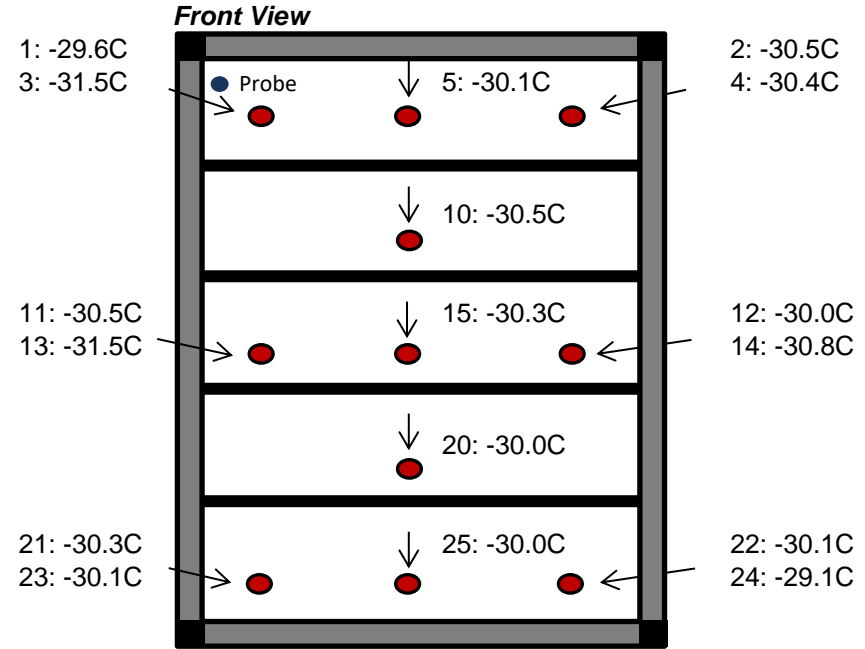
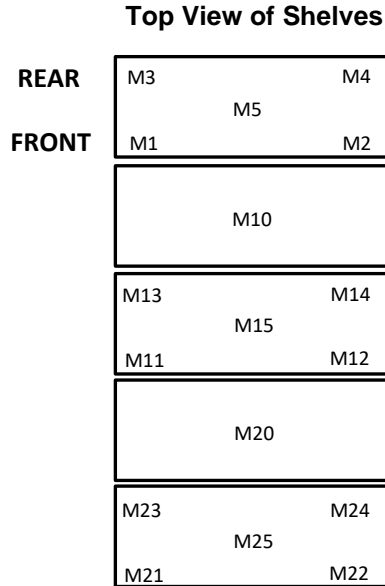

19758-B-20-1

Cabinet Average: -30.3 C
Probe Average: -29.7 C
Peak Variation: +9.6 C / -4.5 C

	M1	M2	M3	M4	M5	M10	M11	M12	M13
Avg	-29.6	-30.5	-31.5	-30.4	-30.1	-30.5	-30.5	-30	-31.5
Max	-20.6	-20.4	-20.7	-20.7	-20.7	-23.5	-24	-24	-24.1
Min	-31.3	-32.8	-34.5	-32.8	-32.3	-32.6	-32.4	-31.6	-34.2

	M14	M15	M20	M21	M22	M23	M24	M25
Avg	-30.8	-30.3	-30	-30.3	-30.1	-30.1	-29.1	-30
Max	-23.9	-24	-24	-23.9	-23.7	-23.8	-23.5	-23.7
Min	-33.2	-32.2	-31.7	-32.4	-32	-32	-30.7	-31.9

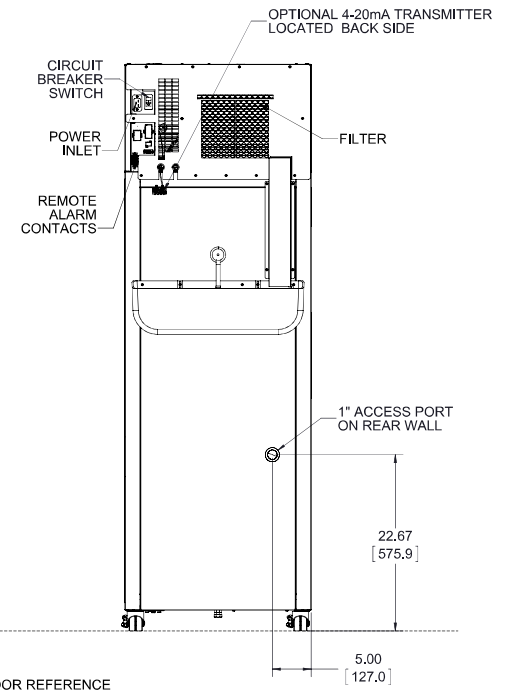
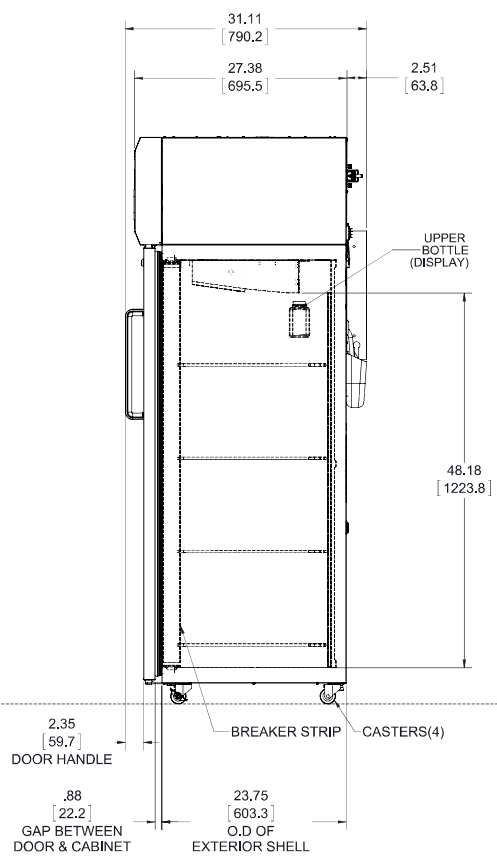
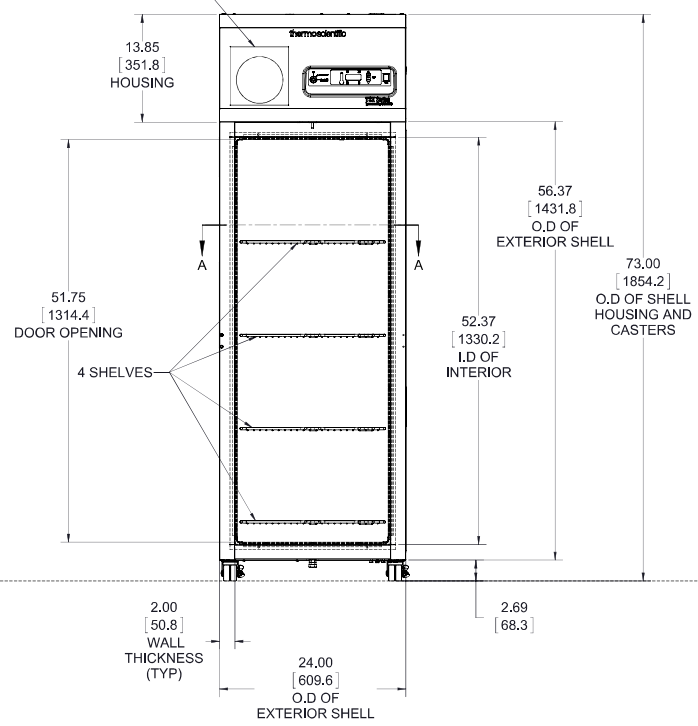
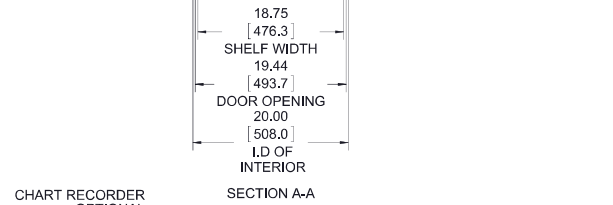
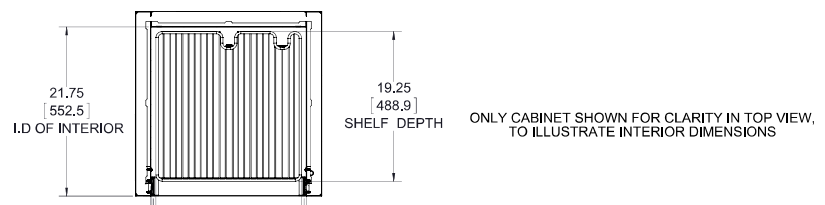

NOTE: DUAL DIMENSION IS INCHES OVER MILLIMETERS
DO NOT USE FOR ENGINEERING PURPOSES. SUBJECT TO CHANGE WITHOUT NOTICE.

12 cu.ft. Lab Freezer
4 Shelves
Single Outer Door
Top Mount Controls

327839G28_rA